

SECTION G-G
SCALE 4 : 3

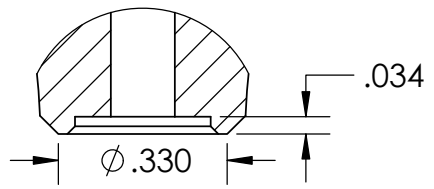

DETAIL J
SCALE 8 : 3

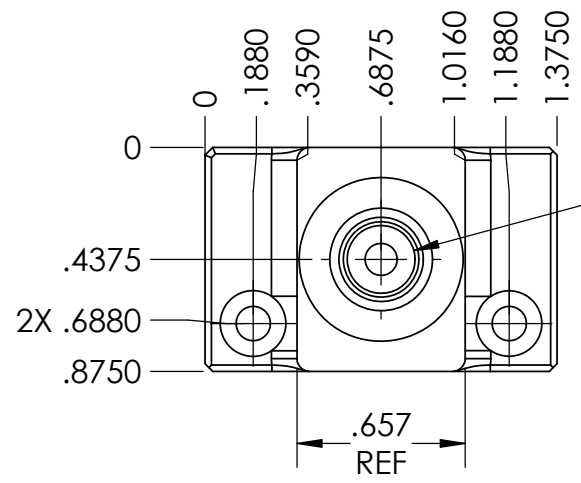
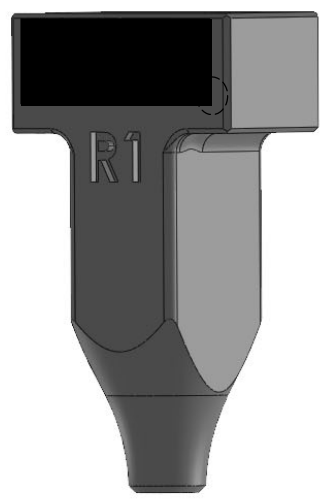

$\phi .125 \nabla 2.135$
 $\phi .265 \nabla .019$

		Electrical Contacts Limited 519-22nd Avenue, Hanover, Ontario, Canada N4N 3T6 <small>THIS DRAWING CONTAINS PROPRIETARY AND CONFIDENTIAL INFORMATION. DUPLICATION, REPRODUCTION OR USE OF THIS DOCUMENT OR ITS CONTENTS IN ANY FORM OTHER THAN PERMITTED BY ELECTRICAL CONTACTS LIMITED IS STRICTLY PROHIBITED.</small>	
		TITLE: GRIPPER	
DESCRIPTION: GRIPPER FOR AUTOMATION		APPROVED BY	
MATERIAL: PLA		DATE	
HARDNESS:		ENGINEERING	
DATE CREATED: 2021-08-26		DATE	
DRAWN BY: N.TRAN		DRAFTSMAN	
CUST. PART #:		DATE	
SHEET SIZE: A		SCALE: 1:1	
TOLERANCES UNLESS SPECIFIED (INCHES)		±.030" ±.010" ±.005" ±.0005" ANGLES ±1°	
SHEET 1 OF 1			

RO	NT	DRAWING CREATION	2021-08-11	
REV	INT	REVISION	YYYY-MM-DD	DCN